

# TECHNICAL DATA SHEET

## DAB12-135

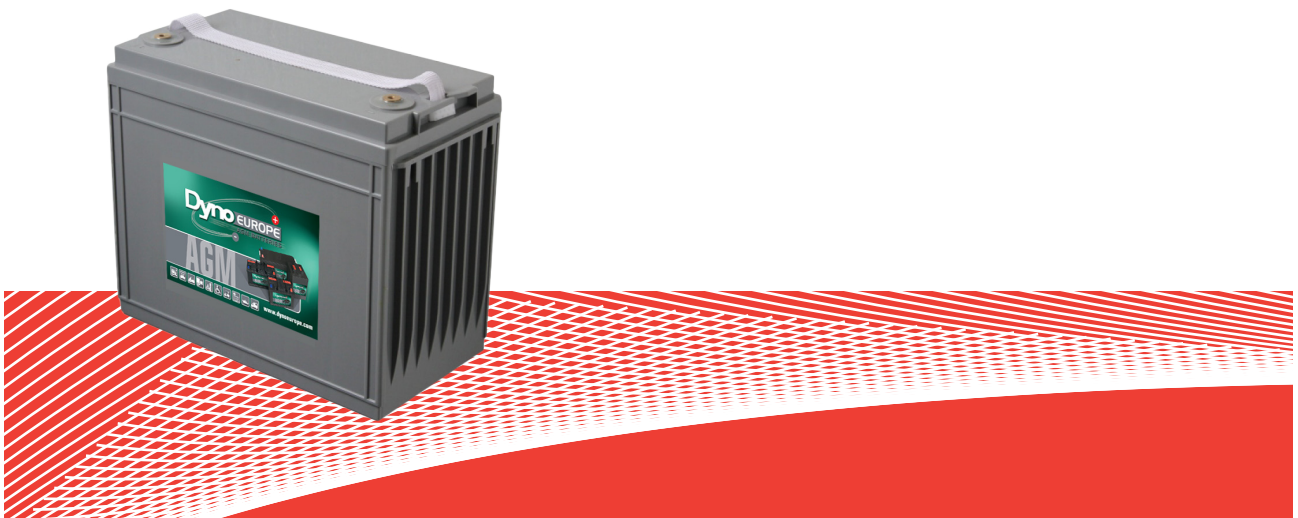

### Specifications

	Dimensions mm - kg						Dimensions Inches - lbs						Cold Cranking Amps		
	Length	Width	Height Auto	Height Insert	Height Battery	Weight	Length	Width	Height Auto	Height Insert	Height Battery	Weight	20°C (68°F)	0°C (32°F)	-18°C (0°F)
<b>DAB12-135</b>	342	173	303	286	283	43.3	13.46	6.81	11.93	16.44	11.26	95.48	1048	951	800

	Volts	Thread size mm	Reserve Capacity - Mins					Capacity - Ampere Hour*						
			75 Amps	25 Amps	20 Amps	15 Amps	8 Amps	100 Hr	48 Hr	20 Hr	10 Hr	5 Hr	3 Hr	1 Hr
<b>DAB12-135</b>	12	8	86	283	377	532	1091	191	179	166	143	136	120	96.5

### Dimensions

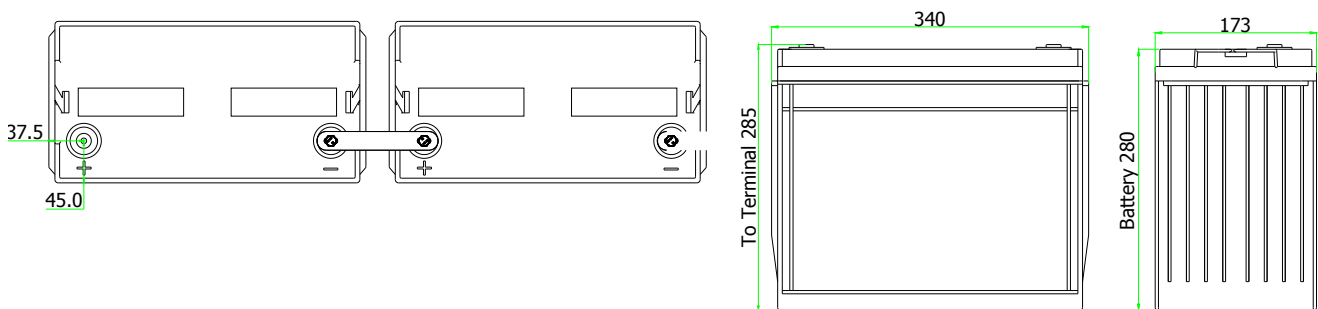

### Applications



**CYCLIC**



**STATIONARY**



**SOLAR**



**MARINE**

### Charging

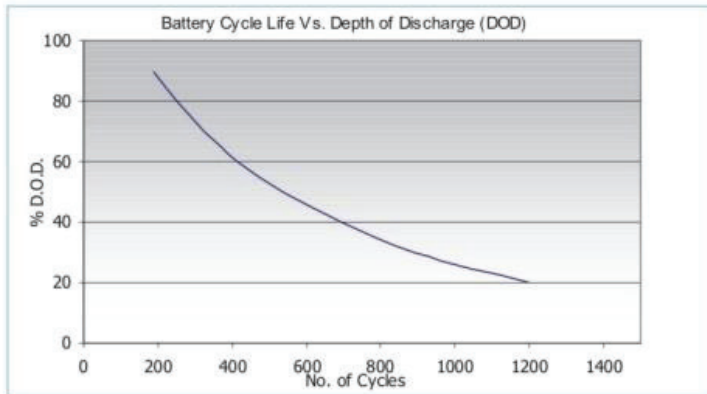

Nominal voltage	6 & 12 volts
Design life	12 Years @ 20°C
Operating temperature	-10 °C to 45°C
Grid alloy	Calcium / Tin lead alloy
Plates	Flat pasted
Separator	Absorbant Glass Mat
Active Material	Very high purity lead
Case and cover	ABS (VO on request)
Charge voltage	Float 2.27 - 2.30 VPC @ 20°C Cycling 2.40 @ 20°C Max. 2.4 VPC Max ripple 3.5%
Electrolyte	Charging V Sulphuric acid analytical grade purity

#### CHARGING CHARACTERISTICS

Floating - The optimum float voltage for a battery is temperature dependant, at 15 - 24°C the recommended value is 2.27 - 2.30V. It is recommended that battery installation sites are temperature controlled, however float voltage can be increased or decreased to compensate for temperature variations. Adjustment is calculated at +/- 3 mV per degree C.

Operating Temperature	Recommended Applied Float Voltage VPC
0-9	2.33-2.35
10-14	2.30-2.33
15-19	2.27-2.30
20-24	2.27-2.30
25-29	2.25-2.27
30-34	2.23-2.25
35-40	2.21-2.23

The most suitable charging method for battery life and performance is the constant voltage method with a limited initial current, usually limited to a maximum of  $C_{20}/4$ . For cyclic use we specify a short constant current phase at the end of normal charging, consult us for further details.

Charging - To obtain maximum cycle life from your battery, it is important that a suitable charging profile is used. For information about our range of chargers and our recommended charging profile, please contact us.